



Cal**Sensors**

SF Pulsable Emitters

Cal Source™ SF-series infrared (IR) emitters are designed to be used as a low cost pulsed source of blackbody radiation for near-to-far infrared applications.

The radiating element in the pulsable emitters is an ultra-thin Cal Sensors specific metallic foil configured so that radiation from the foil is directed out of the package. The foil material has an emissivity of 0.88 and closely emulates a blackbody source in spectral distribution. SF-series emitters are designed to operate at a rated maximum foil temperature of 1000° Kelvin.

Standard SF-series emitters are offered as unsealed TO-5 style assemblies where there is no attenuation from the window material.

The SF pulsable emitter is designed to operate with maximum element temperatures of approximately 1000° K (727° C). Since the radiated energy is proportional to the fourth power of the absolute temperature (T^4), accurate control of the input power and proper heat sinking of the package are essential to maintain consistent output. The heat sink must limit the package to not more than 120°C. The relationship between peak wavelength (λ_{pk} in microns) and temperature (T in ° Kelvin) for the blackbody spectrum is expressed by Wien's law as,

$$\lambda_{pk} \text{ (microns)} \times T \text{ (°K)} = 2898$$

Thus, the wavelength for maximum excitation varies inversely with the absolute temperature. For 1000°K this maximum is at 2.9 microns.

Ph: 707.545.4181
Fx: 707.545.5113

5460 Skylane Blvd.
Santa Rosa, CA 95403

info@calsensors.com
www.calsensors.com

(SF) Pulsable Emitters in TO-5 Package

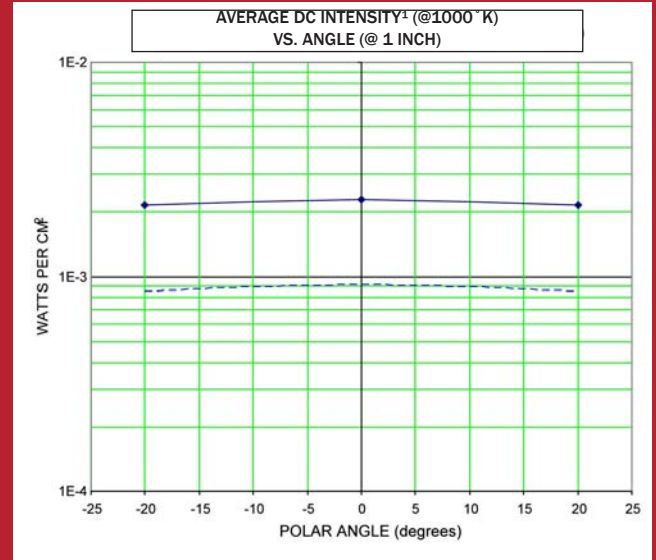
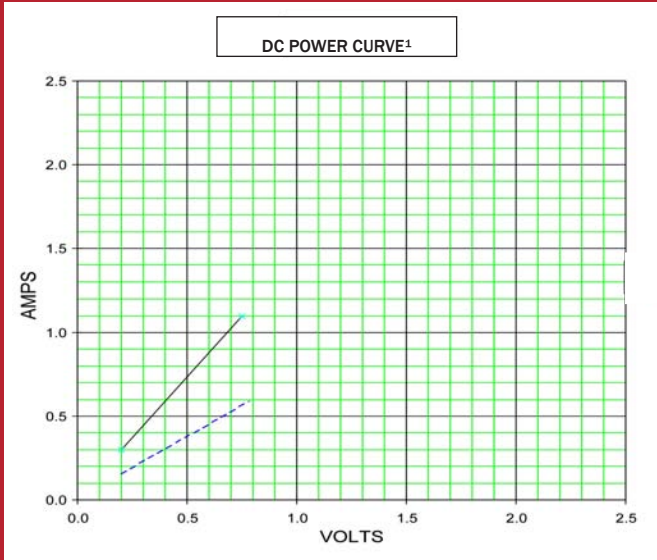

¹1000°K at power indicated (*). Exceeding this value will raise element temperature and decrease source lifetime.

¹ Average of values parallel and perpendicular to axis of element

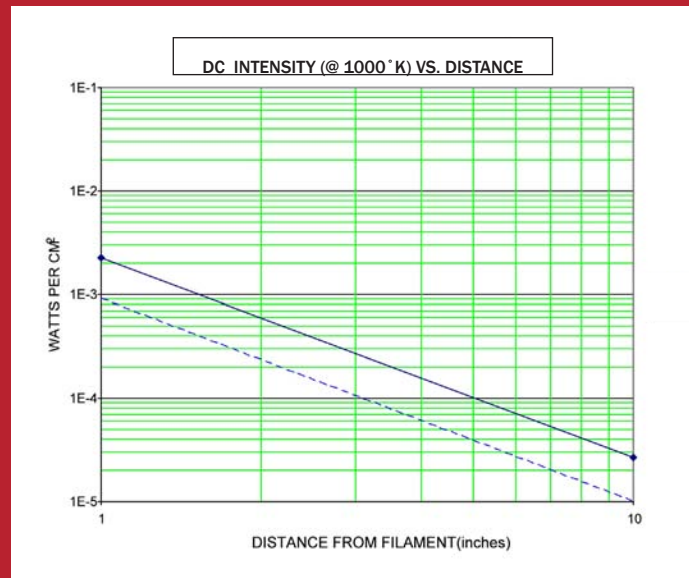
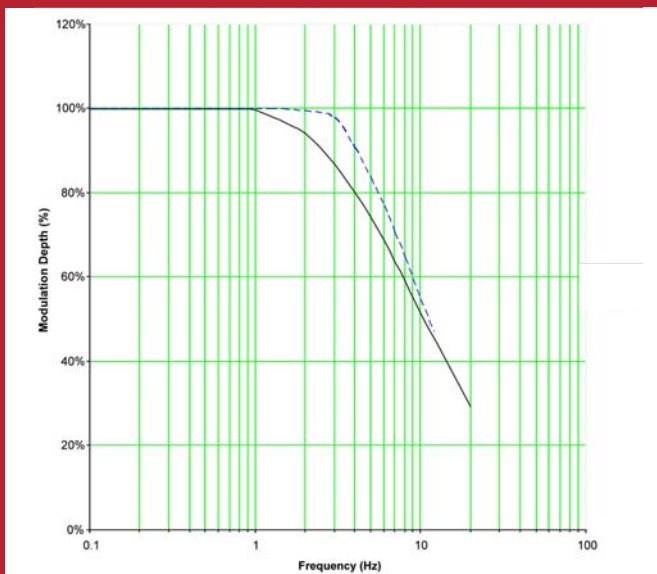

— SF220-5M @ 0.46 watts
 - - - SF240-5M @ 0.83 watts

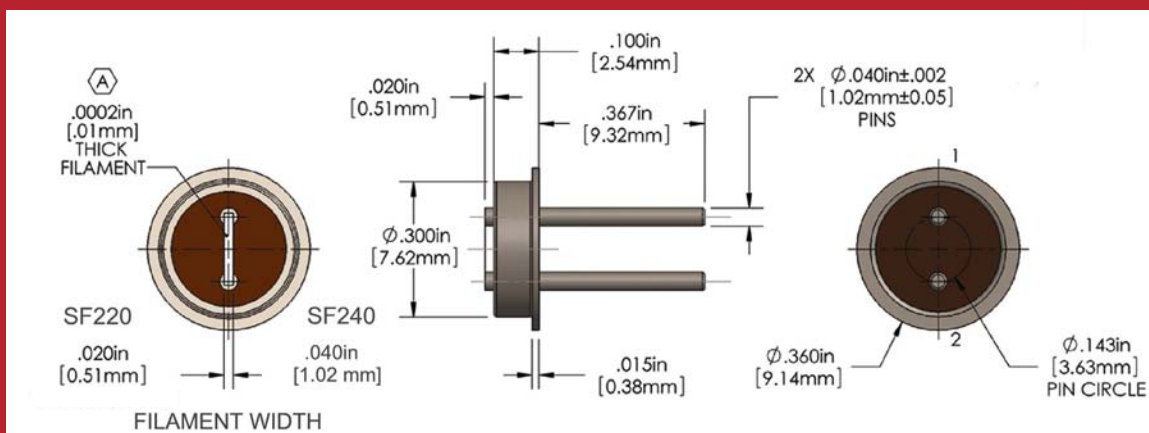

* All specifications subject to change without notice

Rev 1- 6/29/09